

ENCODER TEST MODULE APPLICATION GUIDE

MODEL NUMBER: EM-DR1-ET-5-TB-4469-24V

PART NUMBER: 924-60002-001



BEI INDUSTRIAL ENCODER DIVISION
BEI TECHNOLOGIES, INC.

7230 Hollister Avenue, Goleta, CA 93117-2891

Phone: (800)362-6337 or (800)938-0782

Fax: (800)960-2726 or (805)968-3154

www.beied.com

ENCODER TEST MODULE

TECHNICAL SPECIFICATIONS:

The DIN rail mounted tester module is designed to simply and reliably test the operation of most incremental encoders. The encoder tester provides LED output indicators for two quadrature channels, and an index as an aid for troubleshooting and equipment set-up

MECHANICAL SPECIFICATIONS:

Package dimensions are 114.4 mm high by 99 mm wide by 22.5 mm thick. The package mounts to a DIN rail type EN 50 022 (35mm X 7.5mm). A length of DIN rail is supplied with each tester. The DIN rail section can be mounted directly to the back of a bench test stand with standard sheet metal or wood screws. The tester simply snaps directly to the DIN rail and is ready for use.

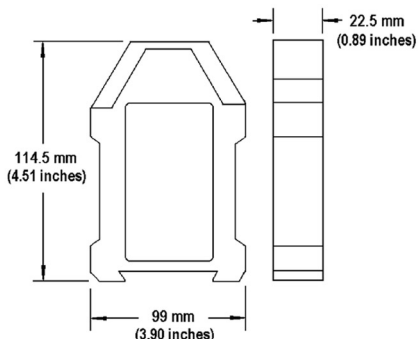

DIN rail mounted encoder tester

ELECTRICAL SPECIFICATIONS:

Power

The encoder tester uses an internal voltage regulator. It is powered by an external power supply of 4.5 to 26 VDC. This unit should never be connected directly to AC power mains. The test module draws approximately 75 mA and a green LED indicates the unit is powered. The encoder under test must also be connected to a power supply (Power supply not included).

DISCLAIMER: This application guide assumes a certain level of technical expertise including the ability to interpret simple electrical schematics and the ability to identify and use electrical components. Should additional assistance be required please contact the factory.

Signal

The encoder tester is designed around the most common type of encoder output – a TTL level (RS422) differential line driver. However, it can be used to test most encoder signal types with the proper connections. Please follow the connection diagrams and the table below as detailed in the specification sheet for the type of encoder signal that you will be testing.

<i>Output Code Format From Encoder</i>	Dual channel in quadrature with index and complements. Data lines are designated A, B, Z, A-, B-, Z at the module
<i>Output Signal Type From Encoder</i>	<ul style="list-style-type: none"> • TTL level (RS422 compatible) differential line driver (Use Connection Instructions #1) • TTL level (RS422 compatible) single ended line driver (Use Connection Instructions #1) • Single ended open collector with pull-up resistors internal to encoder (Use Connection Instructions #2) • Single ended, open collector (Use Connection Instructions #3)
<i>Frequency Response Of Tester</i>	1 MHz, maximum
<i>Power Requirements For Tester</i>	Input supply voltage 4.5 to 26 VDC, 75 mA (typical)
<i>Protection Level</i>	Supply lines protected against over voltage to 60 volts and reverse voltage

CONNECTION INSTRUCTIONS #1

Differential or Single Ended Line Driver

Encoder Output Voltages from 5 VDC to 24 VDC

- 1) Connect the terminals for the encoder tester labeled A-, B-, and Z- to the power supply common from the encoder.

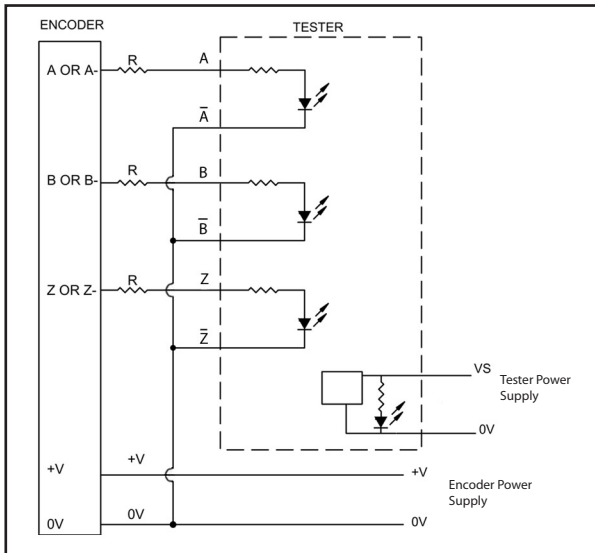

Encoder Signal Voltage	Series Resistance, R	Color Code
5V	None	—
12 – 15 Vdc	1 kohm, 1/2W	BRN-BLK-RED
24 Vdc	2.4 kohm, 1/2 W	RED-YEL-RED

FIGURE 1

- 2) Connect the encoder A, B, and Z channels to the terminals marked A, B, and Z, respectively, on the encoder tester. **NOTE:** If the encoder is designed for an output voltage of 12 to 15 volts, then use the 1 kohm dropping resistor provided with the encoder tester. If the encoder is designed for an output voltage of 24 volts, then use the 2.4 kohm resistor supplied with the tester. These resistors are installed in series with the inputs (See figure 1, components "R").
- 3) Supply input power to the tester and verify that the green LED is lit. Tester is ready to operate.
- 4) Power up the encoder.
- 5) Turn the encoder slowly by hand. The A and B channel LED's should alternately blink on and off with the Z channel lighting up once per complete revolution of the encoder shaft. High resolution (>500 cpt) will blink rapidly. By alternately turning and stopping the shaft, it may be easier to see the on/off operation of the LEDs. If this is not the case, the encoder is faulty and needs to be replaced or repaired. **NOTE:** Encoders do not always have all three channels, A, B, and Z. If a channel fails to light, ensure that the encoder has that channel available. Refer to the BEI *Optical Encoder Design & Specifying Guide* for encoder pinouts and model number information.
- 6) If your encoder has the complementary signals, A-, B-, and Z- you are now ready to test those channels.
- 7) Turn off the power to the encoder.
- 8) Disconnect the encoder's A, B, and Z channels from the tester and connect the encoder's complementary channels in place of those. Connect the encoder's A- channel to the tester's A channel, the B- channel into the tester's B channel and the Z- channel into the tester's Z channel.
- 9) Power up the encoder and turn it slowly by hand as in step 5) above. Note the operation of the LED's.

CONNECTION INSTRUCTIONS #2

Single Ended Open Collector With Internal Pull-up Resistor

- 1) Connect the terminals for the encoder tester labeled A-, B-, and Z- to the power supply common from the encoder (See figure 2, below).
- 2) Connect the encoder A, B, and Z channels to the terminals marked A, B, and Z, respectively, on the encoder tester.
- 3) Supply input power to the tester and verify that the green LED is lit. Tester is ready to operate.

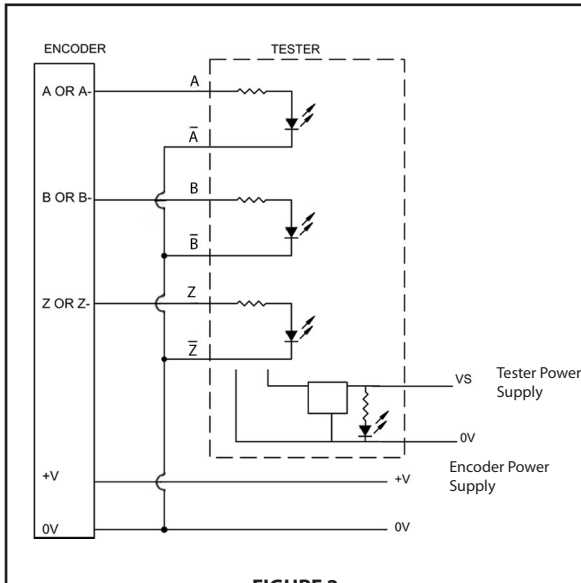

FIGURE 2

- 4) Power up the encoder
- 5) Turn the encoder slowly by hand. The A and B channel LED's should alternately blink on and off with the Z channel lighting up once per complete revolution of the encoder shaft. High resolution (>500 cpt) will blink rapidly. By alternately turning and stopping the shaft, it may be easier to see the on/off operation of the LED's. If this is not the case, the encoder is faulty and needs to be replaced or repaired. **NOTE:** Encoders do not always have all three channels, A, B, and Z. If a channel fails to light, ensure that the encoder has that channel available. Refer to the *BEI Optical Encoder Design & Specifying Guide* for encoder pinouts and model number information.

CONNECTION INSTRUCTIONS #3

Single Ended Open Collector Without Internal Pull-up Resistor

- 1) Connect the terminals for the encoder tester labeled A, B, and Z to the positive side of the power supply common from the encoder (See figure 3, on next page).
- 2) Connect the encoder A, B, and Z channels to the terminals marked A-, B-, and Z-, respectively, on the encoder tester. **NOTE:** If the encoder is designed for an output voltage of 12 to 15 volts, then use the 1 kohm dropping resistor provided with the encoder tester. If the encoder is designed for an output voltage of 24 volts, then use the 2.4 kohm resistor supplied with the tester. These resistors are installed in series with the inputs (See Figure 3, components "R").
- 3) Supply input power to the tester and verify that the green LED is lit. Tester is ready to operate.
- 4) Power up the encoder

- 5) Turn the encoder slowly by hand. The A and B channel LED's should alternately blink on and off with the Z channel lighting up once per complete revolution of the encoder shaft. High resolution (>500 cpt) will blink rapidly. By alternately turning and stopping the shaft, it may be easier to see the on/off operation of the LED's. If this is not the case, the encoder is faulty and needs to be replaced or repaired. **NOTE:** Encoders do not always have all three channels, A, B, and Z. If a channel fails to light, ensure that the encoder has that channel available. Refer to the BEI *Optical Encoder Design & Specifying Guide* for encoder pinouts and model number information.

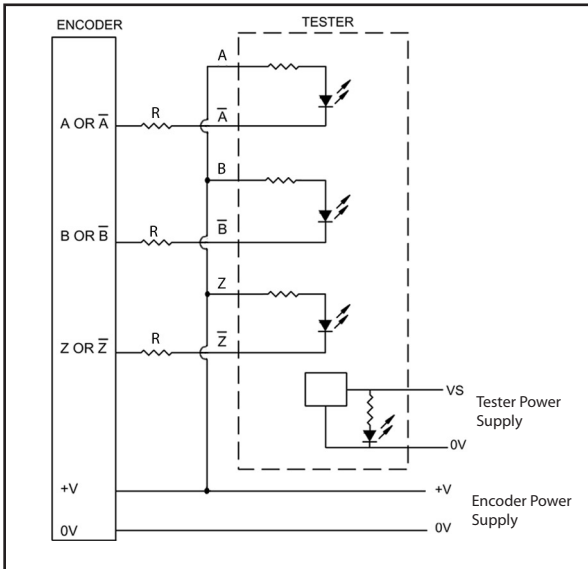

Encoder Signal Voltage	Series Resistance, R	Color Code
5V	None	—
12 – 15 Vdc	1 kohm, 1/2W	BRN-BLK-RED
24 Vdc	2.4 kohm, 1/2 W	RED-YEL-RED

FIGURE 3

BEI INDUSTRIAL ENCODER DIVISION
BEI TECHNOLOGIES, INC.

7230 Hollister Avenue, Goleta, CA 93117-2891

Phone: (800)362-6337 or (800)938-0782

Fax: (800)960-2726 or (805)968-3154

www.beiied.com